

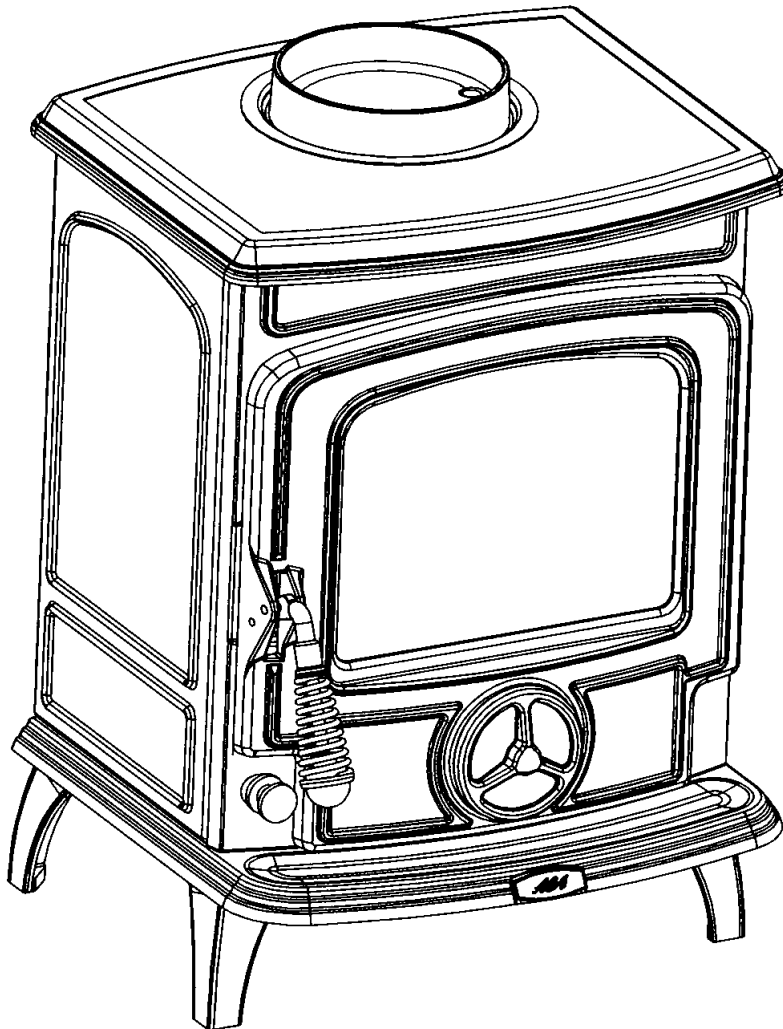

Little Wenlock Solid Fuel Stove



This appliance is hot while in operation and retains its heat for a long period of time after use. Children, aged or infirm persons should be supervised at all times and should not be allowed to touch the hot working surfaces while in use or until the appliance has thoroughly cooled.

INSTALLATION AND OPERATING INSTRUCTIONS

TABLE OF CONTENTS

| | PAGE NO. |
|--|----------|
| 1. General | 3 |
| 2. Pre-Installation Assembly | 3 |
| 3. Flues | 3 |
| 4. Chimney | 3 |
| 5. Top Flue Exit | 4 |
| 6. Rear Flue Exit | 4 |
| 7. Down Draughts | 4 |
| 8. Ventilation & Combustion Air Requirements | 5 |
| 9. Location | 5 |
| 10. Clearance to Combustibles | 5 |
| 11. Stove Dimensions | 5 |
| 12. Floor Protection | 5 |
| 13. Lighting | 6 |
| 14. Primary Air Settings | 6 |
| 15. Recommended Fuels | 6 |
| 16. Outputs | 6 |
| 17. Re-Fuelling | 6 |
| 18. Overnight Burning | 6 |
| 19. Important Notes | 7 |
| 20. Lighting | 8 |
| 21. De-Ashing | 9 |
| 22. Disposal of Ash | 9 |
| 23. Maintenance | 9 |
| 24. Chimney Cleaning | 9 |
| 25. Fire Safety | 9 |
| 26. Glass - Cleaning & Replacement | 9 |
| 27. Enamel Cleaning | 10 |
| 28. Exploded View | 10 |



LITTLE WENLOCK SOLID FUEL NON-BOILER STOVE INSTALLATION & OPERATING INSTRUCTIONS

GENERAL

When installing, operating and maintaining your stove respect basic standards of fire safety. Read these instructions carefully before commencing the installation. Failure to do so may result in damage to persons or property. Consult your local Municipal office and your insurance representative to determine what regulations are in force. Save these instructions for future reference.

The installation must be completed in accordance with current National and European Standards and Local Codes. It should be noted that the requirements and these publications may be superseded during the life of this manual.

PRE-INSTALLATION ASSEMBLY

1. After removing the stove from the packaging, open the fire door and remove all contents from inside.
2. Fit the fire door handle using the screw provided.
3. Remove the stove from the pallet and position it in the final installation position (See Location & Clearance to Combustibles Section).

FLUES

Flues should be vertical wherever possible and where a bend is necessary, it should not make an angle of more than 45° with the vertical. Horizontal flue runs should be avoided except in the case of a back outlet from the appliance, when the length of the horizontal section should not exceed 150mm.

In order to minimise flue resistance and to make sweeping easier it is recommended to use 2 x 45° bends rather than a 90° bend.

The flue termination point must be located to minimise any wind effects. Wind effects of suction, pressure zones and turbulence can be created by the roof and adjacent objects. Wind effects can also be created by natural land contours.

To minimise the wind effects, the flue termination point should be located a minimum of 1000mm from the roof measured vertically and 2300mm measured horizontally. Where this termination point does not suffice it may be necessary to extend the flue pipe so that the termination point is above the apex. See Fig.1.

Fig.1

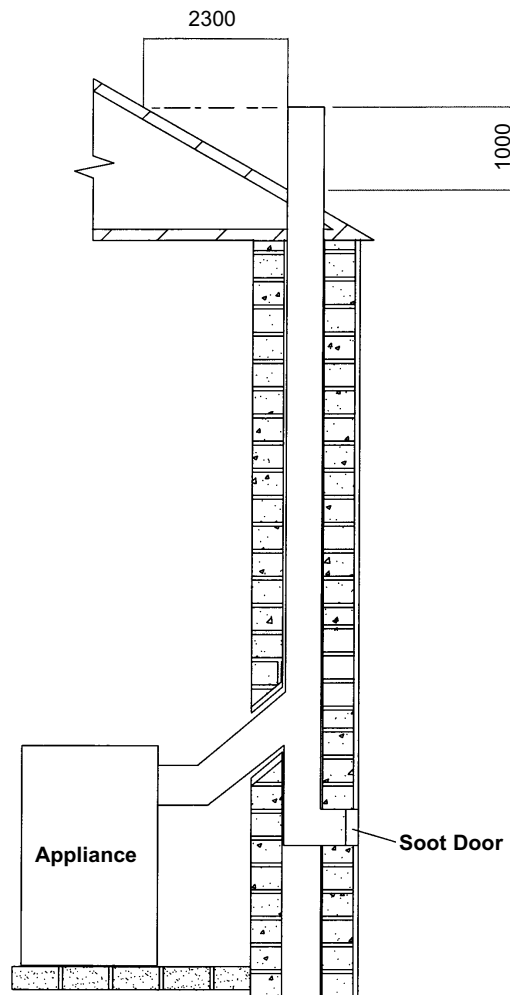

CHIMNEY

The stove is a radiant room heater and must be connected to a chimney of the proper size and type. The chimney must have a diameter of at least 150mm. Never connect to a smaller size chimney. Do not connect to a chimney serving another appliance. Minimum chimney height 4.5 meters from floor on which stove is installed.

A flue that has proved to be unsatisfactory, particularly with regard to down draught should not be used for venting this appliance until it has been examined and any faults corrected.

An existing masonry chimney should be inspected and if necessary repaired by a competent mason or relined using an approved lining system. The stove must be connected to a chimney with a minimum continuous draught of 12 Pascal's. Poor draught conditions will result in poor performance. All register plates, restrictor plates, damper etc., which could obstruct the flue at a future date should be removed before connecting this appliance. If connecting to an existing chimney with a flue diameter of more than 150mm it is necessary to line the flue using a

suitable stainless steel flue liner. Where a masonry chimney is not available a proprietary type 150mm twin wall, fully insulated pipe may be used. The pipe must terminate at a point not lower than the main ridge of adjacent outside obstructions. With such installation, access to the chimney must be provided for cleaning purposes. (See Fig.1)

When flue piping passes through a closure plate with a sliding door, ensure that the pipe continues up and is ultimately connected to the flue liner and well sealed with fire cement.

TOP FLUE EXIT

For the top outlet configuration, remove the blanking plate (part no.10) from the hob, remove the flue spigot (part no.11) from the back plate and fix it to the hob. Fix the outlet blanking plate to back plate (see Fig. 2). Push the flue outlet connector pipe (not supplied) into the flue spigot and cement into place using approved fire cement, ensuring that no cement is blocking the flue passageway.

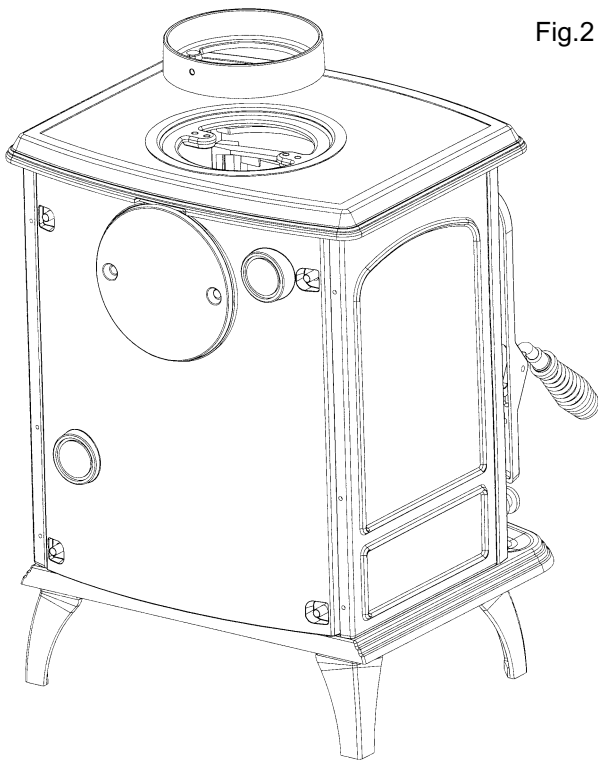
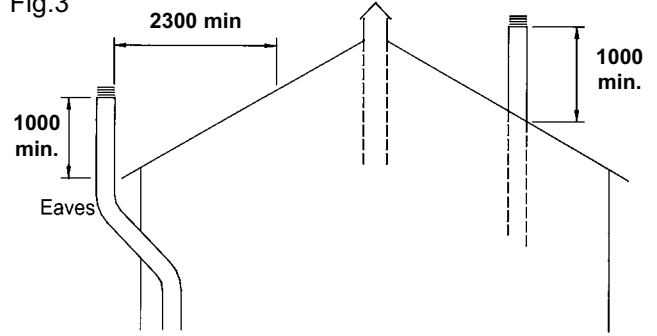

Fig.2

REAR FLUE EXIT

Push the flue connector pipe (not supplied) into the flue spigot and cement into place using approved fire cement ensuring that no cement is blocking the flue passageway.

Fig.3



Pitched roof not exceeding 45° showing external and internal flues and ridge termination

DOWN DRAUGHTS

However well designed constructed and positioned, the satisfactory performance of the flue can be adversely affected by down draught caused by nearby hills, adjacent tall buildings or trees. These can deflect wind to blow directly down the flue or create a zone of low pressure over the terminal. A suitable anti-down draught terminal or cowl will usually effectively combat direct down blow but no cowl is likely to prevent down draught due to a low pressure zone. (See Fig.4)

Fig.4

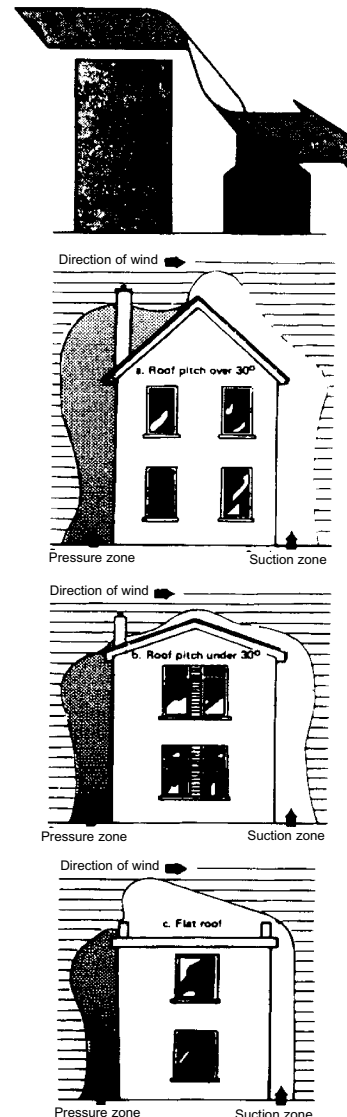

VENTILATION AND COMBUSTION AIR REQUIREMENTS

This appliance is rated at less than 6kW. The minimum effective air requirement is 5.5 cm². If a draught stabiliser is used then this increases to 23.5 cm². When calculating combustion air requirements for this appliance use the following equation: 550mm² per each kW of rated output above 5 kW should be provided, where a flue draught stabiliser is used the total free area shall be increased by 300mm² for each kW of rated output. If there is another appliance using air fitted in the same or adjacent room, it will be necessary to provide an additional air supply. All materials used in the manufacture of air vents should be such that the vent is dimensionally stable, corrosion resistant, and no provision for closure. The effective free area of any vent should be ascertained before installation. The effect of any grills should be allowed for when determining the effective free area of any vent.

Air vents direct to the outside of the building should be located so that any air current produced will not pass through normally occupied areas of the room. An air vent outside the building should not be located less than the dimensions specified within the Building Regulations and B.S. 8303: Part 1 from any part of any flue terminal. These air vents must also be satisfactorily fire proofed as per Building Regulations and B.S. 8303: Part 1.

Air vents in internal walls should not communicate with bedrooms, bedsits, toilets, bathrooms or rooms containing a shower.

Air vents traversing cavity walls should include a continuous duct across the cavity. The duct should be installed in such a manner as not to impair the weather resistance of the cavity.

Joints between air vents and outside walls should be sealed to prevent the ingress of moisture. Existing air vents should be of the correct size and unobstructed for the appliance in use. If there is an extraction fan fitted in the room or adjacent rooms where this appliance is fitted, additional air vents will be required to alleviate the possibility of spillage of products of combustion from the appliance/flue while the fan is in operation. Refer to B.S. 8303 Part 1.

Where such an installation exists, a test for spillage should be made with the fan or fans and other appliances using air in operation at full rate, (i.e. extraction fans, tumble dryers) with all external doors and windows closed.

If spillage occurs following the above operation, an additional air vent of sufficient size to prevent this occurrence should be installed.

LOCATION

There are several conditions to be considered in selecting a location for your stove.

- A. Position in the area to be heated - central locations are usually best. If situated in an alcove, site as far forward as possible, to provide more heat to the room.
- B. Allowances for proper clearances to combustibles.

CLEARANCE TO COMBUSTIBLES

It is recommended that this appliance is sited next to and on a non-combustible surface. A minimum all round clearance of 100mm will allow air circulation and not impede the performance of the stove. If it is necessary to site the stove near to a combustible surface a minimum clearance of 600mm must be maintained. The connector may pass through walls or partitions constructed of combustible materials provided the connector is either listed for wall pass-through or is routed through a device listed for a wall pass-through and is installed in accordance with the conditions of the listing. Any unexposed metal that is used as part of a wall pass-through system is exposed to flue gases shall be constructed of stainless steel or other equivalent material that will resist corrosion, softening, or cracking from flue gas at temperatures up to 982°C.

STOVE DIMENSIONS

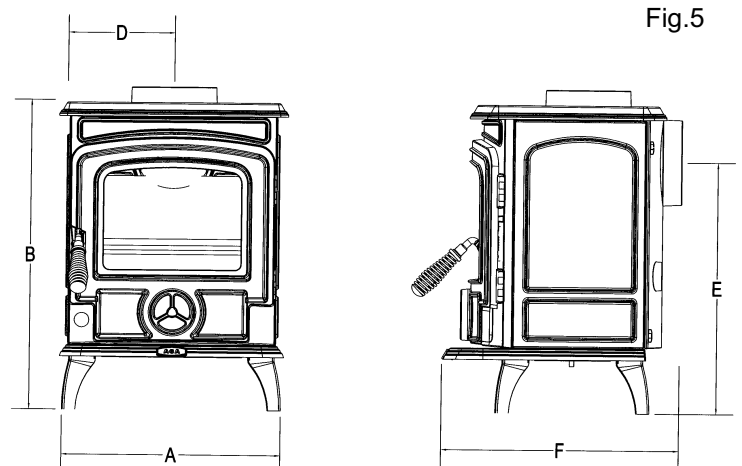

Note: The dimensions stated are in millimeters and may be subject to a slight +/- variation.

FLOOR PROTECTION

It is recommended that this appliance is installed on a solid, level, non combustible hearth conforming to current Building Regulations.

LIGHTING

Check that all dampers and catches are operating correctly and ensure that all flue connections are thoroughly sealed. Open the spin valve.

PRIMARY AIR SETTINGS

The spin valve (Part No. 30, located at the bottom end of the door - Part No. 14) controls the primary and window wash air supply to the stove. For maximum heat output and burn rate rotate the spin valve (Part No. 30) fully in an anti-clockwise direction and for a minimum heat output and burn rate rotate the spin valve clockwise until fully closed. For nominal heat output the spin wheel will need to be open between 1 and 2 turns depending upon the draught of the chimney. You will soon learn spin valve settings to best suit your requirements. (See Fig.6)

Fig.6

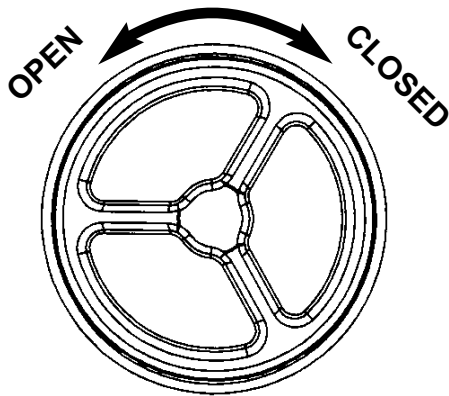

RECOMMENDED FUELS

This appliance has been tested using seasoned wood logs and manufactured briquetted smokeless fuel (Ancit) for closed appliances, sized between 20g and 140g. Other fuels are commercially available and may give similar results. Do not use fuels with a coke ingredient as this may cause the grate to overheat, causing damage. Reduced outputs will result when fuels of lower calorific values are used.

All fuels should be stored under cover and kept as dry as possible prior to use.

Outputs

Nominal heat output

| | |
|--------------------|--------|
| Wood logs | 5.7 kW |
| Solid mineral fuel | 4.1 kW |

Typical refuelling intervals to obtain nominal outputs:

1.5 hours wood
4 hours solid mineral fuel

| | | |
|----------------------|--------------|------------|
| Stove Weight: | Gross | Net |
| | 74 kgs | 66kgs |

RE-FUELLING

Riddle the fire by connecting the grate operating tool onto the rocker connection located at the bottom front of the stove, then gently pull and push the rocker arm until all dead ash has fallen through into the ashpan. Before opening the door, open the spin valve by turning it anti-clockwise, as this will help to eliminate any smoke or fly ash resident in the combustion chamber. Add fuel to fire, taking care not to overfill higher than the front firebars. Close fire door and re-set spin valve to required setting. Do not operate this appliance with the fire door open. (See Fig.7)

Fig.7

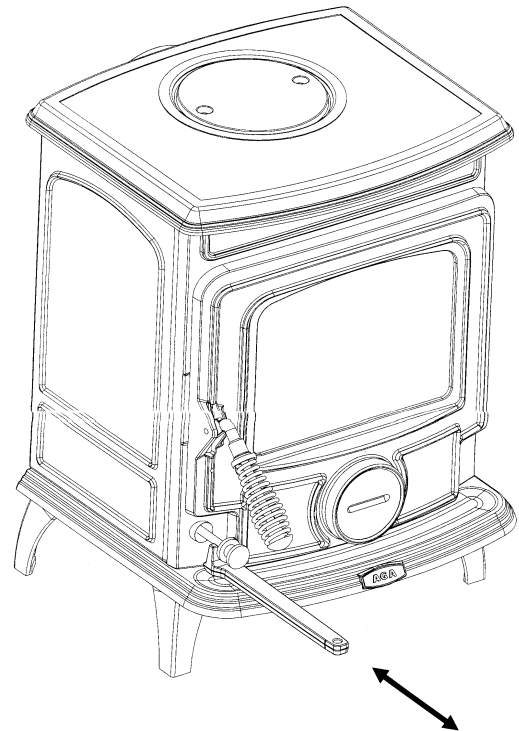

OVERNIGHT BURNING

To achieve an overnight or a slow burn rate, close the spin valve fully, then open about half a turn, or less, depending on draught conditions. If the fuel load is too small or the draught too strong the spin valve may need to be closed even further to sustain the low burn rate. This will be found by trial and error by adjusting the amount of air depending upon the amount of fuel left over at the end of the burning period.

IMPORTANT NOTES

Now that your Aga solid fuel stove is installed and no doubt you are looking forward to many comforts it will provide, we would like to give you some tips on how to get the best results from your stove.

1. We would like if you could take some time to read the operating instructions/hints, which we are confident, will be of great benefit to you.
2. Do not burn fuel with a high moisture content, such as a damp peat or unseasoned timber. This will only result in a build up of tar in the stove and in the chimney and the possibility of a chimney fire.
3. **CLEAN THE FLUE-WAYS OF THE STOVE EVERY WEEK AND ENSURE THAT THERE ARE NO BLOCKAGES. CHECK FLUEWAYS BEFORE LIGHTING ESPECIALLY AFTER A SHUT-DOWN PERIOD. PLEASE REFER TO MANUAL FOR INSTRUCTIONS.**
4. Before loading fresh fuel into the firebox, riddle fully to remove all ashes this will allow better and cleaner burning. See Re-Fuelling Section Page 6.
5. Never allow a build up of ashes in the ash pan, as this will cause the grate to burn out prematurely.
6. Avoid long periods of slow burning of damp or unseasoned fuel as this will result in tarring flueways and chimney i.e. peat or timber.
7. Allow adequate air ventilation to ensure plenty of air for combustion.
8. Do not burn rubbish/house hold plastic.
9. Clean the chimney at least twice a year.
10. Burning soft fuels such as timber and peat will stain the glass. Regular cleaning will prevent permanent staining.
11. Keep all combustible materials a safe distance away from the appliance, please see section for clearances to combustibles.
12. For safety reasons never leave children or the elderly unaccompanied while stove is in use. Use a fireguard.
13. Avoid contact with appliance when in use as the stove reaches very high operating temperatures.
14. This appliance should be regularly maintained by a competent service engineer. Use only replacement parts recommended by AGA. Using unauthorized parts will invalidate your guarantee and may cause damage or injury.

IMPORTANT: [SENO PAINTED STOVES ONLY]

AN ODOUR WILL EMIT FROM STOVE ON FIRST FIRING, WHEN FIRE REACHES MAXIMUM TEMPERATURE OVER A NUMBER OF HOURS THIS ODOUR WILL SUBSIDE. IT IS BEST ADVISED TO OPEN WINDOWS DURING THIS PERIOD.

THIS ODOUR IS UNPLEASANT BUT NOT TOXIC. YOU MAY WISH TO VACATE THE ROOM WHILE THE PAINT CURES.

LIGHTING

IMPORTANT: The first few fires should be relatively small to permit the refractory to set properly and to season the stove.

1. Before lighting the stove, ensure that any build-up in the firebox has been removed and that the ashpan has been emptied.
2. Open the spin valve (Part No. 30) by turning it anti-clockwise.
3. Lay a few crumpled sheets of paper on the hearth and then a few small sticks, kindling or an approved firelighter.
4. Ignite and close the door.
5. Never use inflammable liquid i.e. gasoline, petrol paraffin etc. to start or freshen up a fire in this heater.
6. When the fire is well established add fuel to the firebox and adjust the spin valve to the required setting. (See Re-Fuelling Section Page 6).
7. To shut the fire down, do not add fuel, make sure that the fire door is properly closed and that the spin valve is firmly shut. Cutting off the air supply will reduce the heat output.

DE-ASHING

Never allow the ashpan to over fill as it will cause damage to the grate. Open the fire door (Part No.14) and remove ashpan (Part No.10) using the operating tool (Part No.8). Close the fire door (Part No. 14). When the ash is disposed of, replace the empty ashpan. (See Fig.8) Do not leave the fire unattended with the fire door open, even for a minute.

Fig. 8

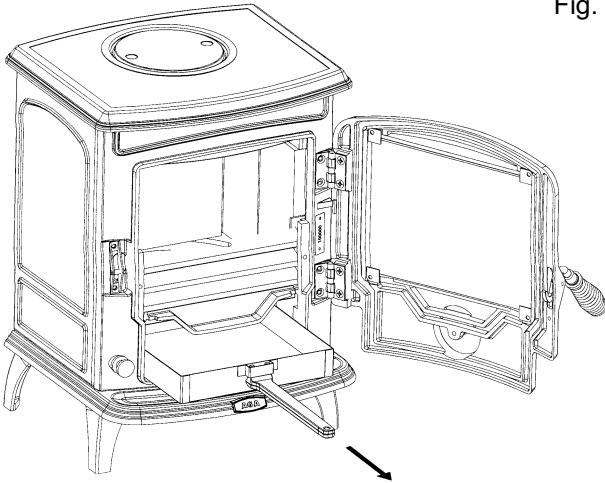

DISPOSAL OF ASH

Ashes should be placed in a metal container with a tight fitting lid. The closed container of ashes should be on a non-combustible floor or on the ground well away from all combustible materials pending final disposal. If the ashes are disposed of by burial in soil or otherwise locally dispersed they should be retained in the closed container until all cinders have thoroughly cooled.

MAINTENANCE

CREOSOTE: Formation and Need for Removal

When some fuels are burned slowly, they produce tar and other organic vapours, which combine with expelled moisture to form creosote. The creosote vapours condense in the relatively cool chimney flue of a slow-burning fire. As a result, creosote residue accumulates on the flue lining. When ignited creosote makes an extremely hot fire.

CHIMNEY CLEANING

Chimney and connector should be cleaned at least twice a year. Once before heating season and once after. The chimney connector and chimney should be inspected at least monthly during the heating season to determine if a creosote build-up has occurred. Remove the cast iron baffle plate (Part No.18) located at the top end of the firebricks (Part No.s 11 & 12) before chimney cleaning.

When inspecting a masonry chimney, start at the cleanout door, normally found at the base of the chimney, or on the outside. If your chimney does not have a clean-out door one should be provided.

REMEMBER COAL GASES ARE TOXIC.

FIRE SAFETY

To provide reasonable fire safety the following should be given serious consideration:

1. The installation of smoke detectors.
2. A conveniently located fire extinguisher to contend with small fires resulting from burning embers.
3. A practical evacuation plan.
4. A plan to deal with a chimney fire as follows:
 - a. Notify the fire department.
 - b. Prepare occupants for immediate evacuation
 - c. Close all openings into the stove.
 - d. While awaiting the fire department watch for ignition to adjacent combustibles from overhead stove pipe or from embers or from sparks from the chimney.

GLASS

1. How to clean:

The glass will clean itself when there is sufficient heat generated by burning fuel. If a build-up of creosote occurs on the glass it may be due to draft conditions, poor quality fuel or very slow burning for long time. Only clean glass when the stove is thoroughly cooled. Clean with a liquid detergent taking care not to scratch the glass with any coal ash deposits.

2. Glass Replacement: (See Fig.9)

- a. Open the door (Part No.14) fully.
- b. Remove the four corner screws and clips and carefully remove the broken glass.
- c. Clean the glass recess in the door.
- d. Attach adhesive thermal tape to the perimeter of the replacement glass.
- e. Place the thermal tape side of the glass into the door recess and replace the four corner clips.
- f. Tighten screws.
- g. Replace glass only with ceramic glass 5mm thick.

Fig.9

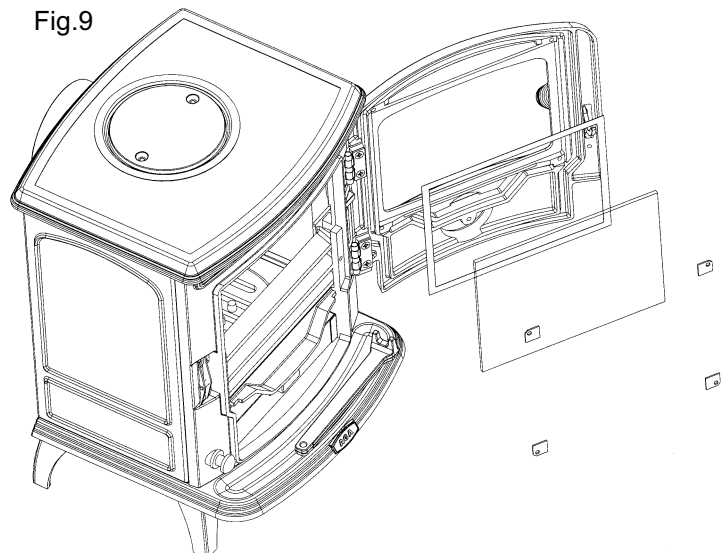

ENAMEL CLEANING

General cleaning must be carried out when the stove is cool.

If this stove is finished in a high gloss vitreous enamel, to keep the enamel in the best condition observe the following tips:

1. Wipe over daily with a soapy damp cloth, followed by a polish with a clean dry duster.
2. For stubborn deposits a soap impregnated pad can be carefully used on the vitreous enamel.

3. Use only products recommended by the Vitreous Enamel Association, these products carry the vitramel label.



4. **DO NOT USE ABRASIVE PADS OR OVEN CLEANSERS CONTAINING CITRIC ACID ON ENAMELLED SURFACES. ENSURE THAT THE CLEANSER MANUFACTURERS INSTRUCTIONS ARE ADHERED TO.**

LITTLE WENLOCK SOLID FUEL STOVE EXPLODED VIEW

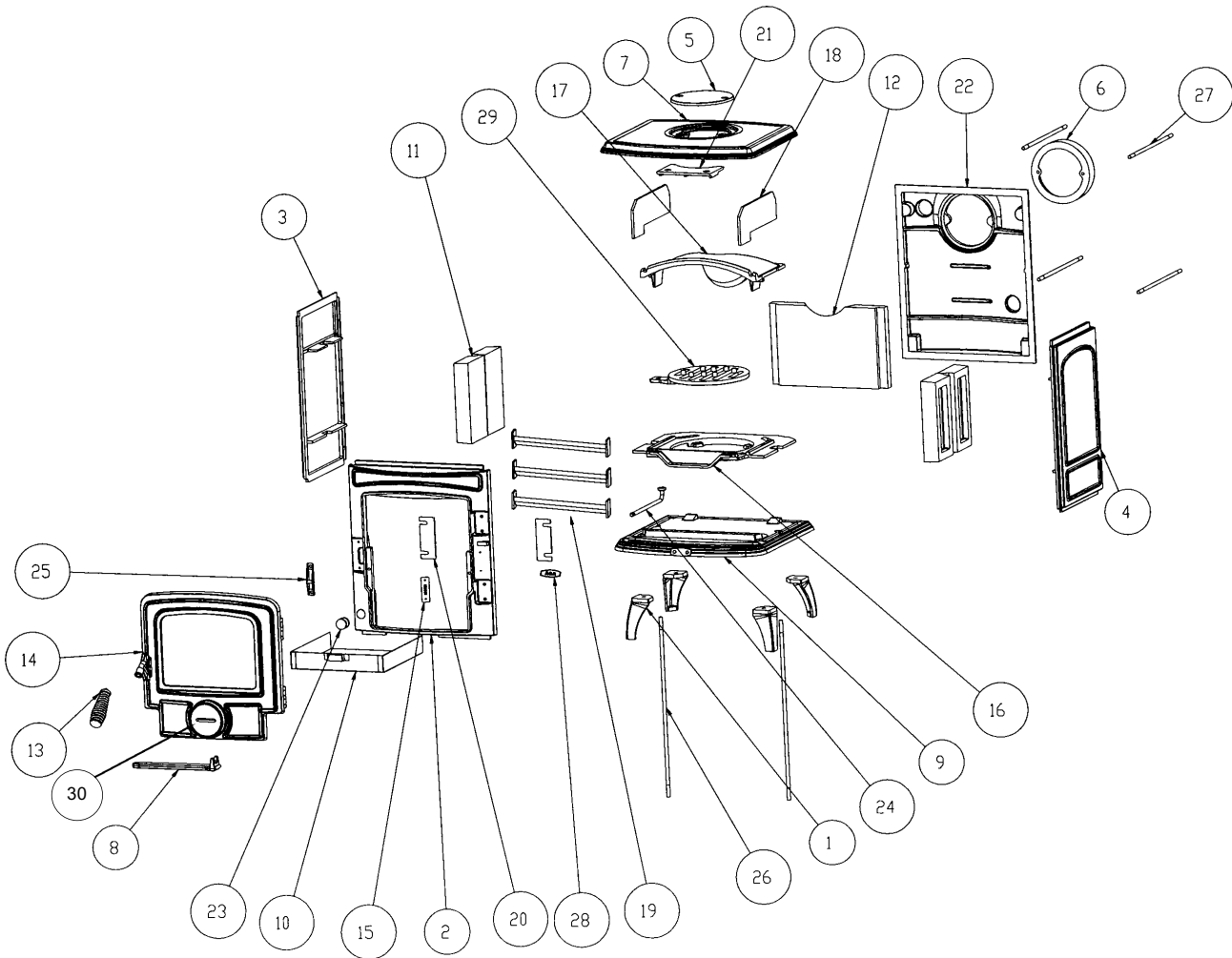

- | | | |
|-----------------------|------------------------------|--------------------------|
| 1. LEG (SHORT) | 11. BRICK SIDE | 21. HOB PROTECTION PLATE |
| 2. FRONT FRAME | 12. BRICK BACK | 22. BACK PANEL |
| 3. LH SIDE | 13. COIL HANDLE ASSEMBLY | 23. PULL ROD KNOB |
| 4. RH SIDE | 14. DOOR ASSEMBLY | 24. GRATE CONNECTING ROD |
| 5. HOB BLANKING PLATE | 15. SERIAL NUMBER PLATE | 25. DOOR CATCH |
| 6. FLUE SPIGOT | 16. GRATE SUPPORT PLATE | 26. LONG TIE BOLT |
| 7. HOB | 17. TOP BAFFLE | 27. TIE ROD (M8 * 260mm) |
| 8. OPERATING TOOL | 18. BAFFLE PROTECTION PLATES | 28. AGA STOVE BADGE |
| 9. BASE | 19. FIRE FENCE x 3 | 29. GRATE |
| 10. ASHPAN | 20. FIRE FENCE RETAINER | 30. SPIN VALVE |



Aga,
Station Road,
Ketley, Telford,
Shropshire, TF1 5AQ,
UK